

# United States Court of Appeals for the Federal Circuit

2009-1099, -1108, -1119

SEB S.A.,

Plaintiff/Counterclaim Defendant-  
Cross Appellant,

and

T-FAL CORPORATION,

Counterclaim Defendant,

v.

MONTGOMERY WARD & CO., INC.,

Defendant,

and

GLOBAL-TECH APPLIANCES, INC.,

Defendant-Appellant,

and

PENTALPHA ENTERPRISES, LTD.,

Defendant/Counterclaimant-  
Appellant.

Norman H. Zivin, Cooper & Dunham LLP, of New York, New York, argued for plaintiff/counterclaim defendant-cross appellant. With him on the brief was Wendy E. Miller.

William Dunnegan, Dunnegan LLC, of New York, New York, argued for defendant-appellant and defendant/counterclaimant-appellant. With him on the brief was Laura Scileppi.

Appealed from: United States District Court for the Southern District of New York

Judge Stephen C. Robinson

# United States Court of Appeals for the Federal Circuit

2009-1099, -1108, -1119

SEB S.A.,

Plaintiff/Counterclaim Defendant-  
Cross Appellant,

and

T-FAL CORPORATION,

Counterclaim Defendant,

v.

MONTGOMERY WARD & CO., INC.,

Defendant,

and

GLOBAL-TECH APPLIANCES, INC.,

Defendant-Appellant,

and

PENTALPHA ENTERPRISES, LTD.,

Defendant-Counterclaimant-  
Appellant.

Appeals from the United States District Court for the Southern District of New York in 99-CV-9284, Judge Stephen C. Robinson.

---

DECIDED: February 5, 2010

---

Before RADER, BRYSON, and LINN, Circuit Judges.

RADER, Circuit Judge.

This case began in August of 1999 when Plaintiff SEB S.A. (“SEB”) sued defendants Montgomery Ward & Co., Inc. (“Montgomery Ward”), Global-Tech Appliances, Inc. (“Global-Tech”), and Pentalpha Enterprises, Ltd. (“Pentalpha”) for infringement of U.S. Patent No. 4,995,312 (the “’312 patent”). Almost seven years later, a jury found that Pentalpha had willfully infringed, and induced infringement of, claim 1 of the ’312 patent and awarded SEB \$4.65 million in damages. Pentalpha filed post-trial motions on a number of grounds. The district court granted them in part, reducing the amount of damages by \$2 million. SEB S.A. v. Montgomery Ward & Co., No. 99-9284, 2007 WL 3165783 (S.D.N.Y. Oct. 9, 2007) (“JMOL Opinion”). The district court awarded SEB enhanced damages and attorneys’ fees, but later vacated that award in light of this court’s decision in In re Seagate Technology, LLC, 497 F.3d 1360 (Fed. Cir. 2007) (en banc). SEB S.A. v. Montgomery Ward & Co., No. 99-9284, 2008 WL 4540416 (S.D.N.Y. Oct. 1, 2008) (“Enhanced Damages Opinion”). On appeal, Pentalpha raises a host of issues that relate to the jury verdict and the district court’s post-trial rulings. SEB cross-appeals the district court’s enhanced damages ruling. Detecting no reversible error in the district court proceedings, this court affirms.

I.

SEB is a French company that specializes in home-cooking appliances. It sells products in the United States through an indirect subsidiary, T-Fal Corp. (“T-Fal”). SEB owns the ’312 patent, entitled “Cooking Appliance with Electric Heating,” which claims a deep fryer with an inexpensive plastic outer shell, or skirt. In the past, skirts for

deep fryers were made of plastic material capable of continuously withstanding temperatures higher than 150° C. These heat resistant plastics, however, are expensive and therefore incompatible with large-scale manufacture of low-priced fryers.

The skirt disclosed in the '312 patent, labeled with the number 3 in the cross-section shown below, is well-insulated from the heat of the fryer's metal pan (1).

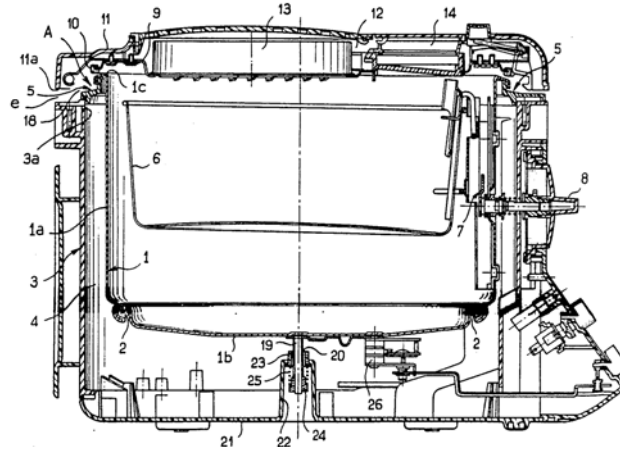

The '312 patent explains construction of a deep fryer with a well-insulated skirt. A ring of heat-insulating and heat-resistive material (5) joins the top edge of the skirt to the top edge of the pan. Other than that ring, however, the skirt is “completely free with respect to the pan.” '312 patent col.1 l.65-col.2 l.2. The skirt and the pan are separated by “an air space of sufficient width to limit the temperature of the skirt.” Id. at col.1 ll.60-64. Thus, because of the insulation provided by air space, the skirt “can be fabricated from inexpensive ordinary-grade plastic material [that] does not afford resistance to high temperatures.” Id. at col.4 ll.32-35.

Claim 1 of the '312 patent, the only claim at issue, reads as follows (emphasis added):

An electrical deep fryer comprising a metal pan (1) having a wall, and an electric heating resister [sic] (2) that heats said wall directly by conductive heating to a temperature higher than 150° C., said pan (1) being

surrounded by a plastic skirt (3), wherein said skirt (3) is of plastic material which does not continuously withstand a temperature of 150° C., said skirt (3) entirely surrounding the lateral wall (1a) and the base (1b) of the pan and being separated from said wall and said base by an air space (4) of sufficient width to limit the temperature of the skirt (3) to a value which is compatible with the thermal resistance of the plastic material of the skirt (3), said skirt (3) being completely free with respect to the pan (1) with the exception of a ring (5) which joins only the top edge (3a) of the skirt to the top edge (1c) of the pan and to which this latter is attached, said ring (5) being of heat-insulating material which is continuously resistant to the temperature of the top edge (1c) of the pan (1).

Defendant Pentalpha is a Hong Kong corporation and a subsidiary of defendant Global-Tech, a British Virgin Islands corporation, which was formerly known as Wing Shing International, Ltd. (For convenience, this opinion will refer to Pentalpha and Global-Tech collectively as “Pentalpha.”) Pentalpha began selling its accused deep fryers to non-party Sunbeam Products, Inc. (“Sunbeam”) in 1997. In developing its deep fryer, Pentalpha purchased an SEB deep fryer in Hong Kong and copied its “cool touch” features. Shortly after agreeing to supply Sunbeam, Pentalpha obtained a “right-to-use study” from an attorney in Binghamton, New York. The attorney analyzed 26 patents and concluded that none of the claims in those patents read on Pentalpha’s deep fryer. Pentalpha, however, did not tell the attorney that it had copied an SEB deep fryer.

Sunbeam resold the Pentalpha deep fryers in the United States under its own trademarks, “Oster” and “Sunbeam.” On March 10, 1998, SEB sued Sunbeam in the United States District Court for the District of New Jersey, alleging that Sunbeam’s sales infringed the ’312 patent (the “Sunbeam Suit”). See SEB S.A. v. Sunbeam Corp., No. 2:98-CV-1050 (date closed May 28, 2002). Pentalpha was notified of the Sunbeam Suit on April 9, 1998. That suit ended in a settlement in which Sunbeam agreed to pay SEB \$2 million.

Pentalpha also sold the same deep fryers to non-party Fingerhut Corp. (“Fingerhut”) and defendant Montgomery Ward. These sales to Fingerhut and Montgomery Ward occurred after Pentalpha learned of the Sunbeam Suit. Like Sunbeam, Fingerhut and Montgomery Ward also sold the products under their own trademarks, CHEF’S MARK and ADMIRAL. Pentalpha sold these deep fryers to its three customers free on board Hong Kong or mainland China. “Free on board,” or “f.o.b.,” is a “method of shipment whereby goods are delivered at a designated location, usually a transportation depot, at which legal title and thus the risk of loss passes from seller to buyer.” Litecubes, LLC v. N. Light Prods., Inc., 523 F.3d 1353, 1358 n.1 (Fed. Cir. 2008).

## II.

SEB filed a motion for a preliminary injunction on September 10, 1999. Following a claim construction hearing, the district court granted SEB’s motion, holding that SEB was likely to prove at trial that Pentalpha’s deep fryers infringe at least claim 1 of the ’312 patent. SEB S.A. v. Montgomery Ward & Co., 77 F. Supp. 2d 399 (S.D.N.Y. 1999) (“Preliminary Injunction Opinion”). This court affirmed the preliminary injunction order without opinion. SEB, S.A. v. Montgomery Ward & Co., Inc., 243 F.3d 566 (Fed. Cir. 2000) (Rule 36).

Pentalpha then redesigned its deep fryer by replacing the ring that separated the skirt and the pan with six blocks or ring segments. SEB sought to supplement the original preliminary injunction to include Pentalpha’s modified deep fryer. The district court granted SEB’s application for supplemental injunctive relief in 2001, finding that SEB was likely to prove at trial that the modified fryer infringes at least claim 1 of the

'312 patent under the doctrine of equivalents. SEB S.A. v. Montgomery Ward & Co., 137 F. Supp. 2d 285 (S.D.N.Y. 2001) ("DOE Opinion"). Pentalpha's primary argument, which the district court did not adopt, was based on prosecution history estoppel. Pentalpha did not appeal the district court's ruling of infringement by equivalents.

Discovery closed on October 30, 2001. On April 17, 2006, the district court commenced a trial. During trial, the record shows that the jury received evidence of Pentalpha's sales to Sunbeam, Fingerhut, and Montgomery Ward. Following the close of evidence, Pentalpha moved for judgment as a matter of law ("JMOL") on SEB's claim that Pentalpha had induced infringement of the '312 patent through those sales. Pentalpha's JMOL motion was based on the lack of evidence that anyone at Pentalpha "had any knowledge whatsoever with respect to the existence of the patent." J.A. 2209. The district court noted at the Rule 50(a) motion proceedings that "there is no evidence that [Pentalpha] was aware of [the '312] patent" before April 9, 1998. Nonetheless, the court held that there was evidence to support SEB's theory of inducement, which the court characterized as follows:

[SEB is] saying that you could infer the specific intent to . . . encourage the infringement by the fact that [Pentalpha's president] doesn't disclose that [Pentalpha copied the SEB product] to the people doing the [patent] search. [Pentalpha] wants them to do a search that . . . is doomed to failure, and that that is enough, that a reasonable jury could infer that, specific intent. . . . Here is the argument. There are a zillion patent attorneys in New York City, [yet] [t]hey go to this guy in the middle of nowhere to do this patent search. . . . I don't know what happened. I'm not in [Pentalpha's President's] head. I don't know what he did. . . . I think it is . . . a reasonable argument, could a jury infer from those actions, if they chose to believe them in the way the plaintiffs want, that that was an indication that [he] understood that he was likely violating a patent, in fact violating a patent.

The district court therefore allowed SEB's inducement claim to reach the jury.

The jury found that Pentalpha, with both its original and modified deep fryers, willfully infringed claim 1 of the '312 patent. The jury also found that Pentalpha induced others to infringe with both versions of the fryers. As damages, the jury awarded SEB a total of \$4.65 million as a reasonable royalty, with \$3.6 million attributable to Sunbeam's sales of Pentalpha's deep fryers, \$540,000 to Fingerhut's sales, and \$510,000 to Montgomery Ward's sales.

Pentalpha then renewed its motion for JMOL and moved for a new trial, arguing that SEB did not adequately prove inducement under 35 U.S.C. § 271(b). Pentalpha also sought an offset of damages in an amount equal to the \$2 million that SEB received in its settlement with Sunbeam. SEB filed a cross motion for enhanced damages, attorneys' fees, prejudgment interest, and injunctive relief.

In response to Pentalpha's post-trial motions, the district court reduced the damages award by \$2 million. JMOL Opinion, 2007 WL 3165783, at \*5. The trial court denied the rest of Pentalpha's post-trial motions. Id. at \*12. The district court granted SEB's cross-motion in part, based on the reduced award, id. at \*10-12, but later vacated its award of enhanced damages and attorneys' fees based on Seagate, Enhanced Damages Opinion, 2008 WL 4540416, at \*4. Thus, the district court entered judgment against Pentalpha in the amount of \$4,878,341. These appeals followed.

### III.

As a threshold matter, this court needs to address a claim construction issue. The district court, as a part of its preliminary injunction order in 1999, construed the limitation "completely free with respect to the pan" in claim 1 to mean "there are no thermal bridges between the skirt and the pan." Preliminary Injunction Opinion, 77 F.



Supp. 2d at 405. A thermal bridge is an element that conducts heat. As a matter of context, this court notes that a vertical stabilizing screw secures the skirt of Pentalpha's fryer to the base of the pan. This screw, however, is not a thermal bridge. Thus, the stabilizing screw does not preclude the conclusion that the skirt is "completely free with respect to the pan" under the district court's claim construction. But if "completely free" means instead "no solid material between the pan and the skirt," as Pentalpha contends, then the stabilizing screw absolves Pentalpha's deep fryer of infringement.

This court, of course, reviews claim construction without deference. Cybor Corp. v. FAS Techs., Inc., 138 F.3d 1448, 1455-56 (Fed. Cir. 1998) (en banc). This court's prior affirmance of the district court's preliminary injunction order does not make the district court's claim construction in its 1999 opinion the law of the case. See Int'l Commc'n Materials, Inc. v. Ricoh Co., 108 F.3d 316, 319 (Fed. Cir. 1997) (claim construction for a preliminary injunction is not definitive "without the more complete record that the district court deemed necessary to its own final decision"). The words of a claim receive the meaning discernible by a person of ordinary skill in the art who has read the entire patent, including the specification, at the time of the invention. Phillips v. AWH Corp., 415 F.3d 1303, 1312-13 (Fed. Cir. 2005) (en banc). The claims themselves, both asserted and unasserted, govern the meaning of claim terms. Id. at 1314.

This court perceives a slight internal inconsistency with the district court's claim construction of "completely free" in the phrase "said skirt (3) being completely free with respect to the pan (1) with the exception of a ring (5)." The claim requires the ring to be "heat-insulating" and "continuously resistant to the temperature of the . . . pan." Thus,

the ring is not a thermal bridge. If “completely free” merely meant “no thermal bridges between the skirt and the pan,” the claim would not need to exclude expressly the ring from the completely free limitation.

Despite this minor inconsistency, the district court’s construction of “completely free” rings true. Claim 8 of the ’312 patent, which depends from claim 1, adds an insulated stabilizing screw between the base of the pan and the base of the skirt. ’312 patent col.6 ll.19-24. With this context, a person of ordinary skill in the art would not read the “completely free” limitation of claim 1 to mean “no solid material between the pan and the skirt” because that reading would not allow for the vertical rod of claim 8. See Phillips, 415 F.3d at 1314 (“Differences among claims can . . . be a useful guide in understanding the meaning of particular claim terms.”).

Moreover, the only embodiment in the specification includes solid material between the pan and the skirt, namely, the vertical rod, id. at col.3 ll.55-65, as well as a thermostat attached to the base of the pan, id. at col.4 ll.3-7. “[A] construction that would not read on the preferred embodiment would rarely if ever be correct and would require highly persuasive evidentiary support.” Chimie v. PPG Indus., Inc., 402 F.3d 1371, 1377 (Fed. Cir. 2005) (internal quotations and alterations omitted). Thus, with the preferred embodiment showing a vertical stabilizing screw, the “completely free” limitation cannot be read so broadly as to exclude this preferred embodiment.

Finally, the specification repeatedly highlights the inventiveness of eliminating thermal bridges to prevent heat transfer to the plastic skirt. For example, the specification notes that in the prior art, “the attachment of the metal pan within the plastic skirt is such that numerous thermal bridges exist between said pan and said

skirt.” ’312 patent col.1 ll.38-40. Those thermal bridges required the skirt to be “formed of [costly] plastic material.” Id. at col.1 ll.41-42. Following the theme of preventing heat transfer, the specification discusses a thermostat between the pan and the skirt but emphasizes its placement “remote from the base 21 of the skirt 3 of plastic material in order to prevent any thermal bridge which would be liable to heat this plastic material to an excessive extent.” Id. at col.4 ll.3-8. Thus, the patent stresses that eliminating thermal bridges is not the same as eliminating any solid material.

Read in light of the entire specification and with an eye to the preferred embodiment, then, the term “completely free” means “practically or functionally free.” Indeed, the specification uses the two terms “completely” and “practically” interchangeably. Compare ’312 patent col. 1 ll.65-66 (“Said skirt is completely free with respect to the pan . . . .”) (emphasis added) with id. at col. 4 ll.28-35 (“[I]n addition to the fact that the skirt 3 is practically free with respect to the pan 1 or in other words that no thermal bridge is created between the pan and the skirt, this latter can be fabricated from inexpensive ordinary-grade plastic material, which does not afford resistance to high temperatures.”) (emphasis added). This court often assumes that different terms convey different meanings. Symantec Corp. v. Computer Assocs. Int’l, Inc., 522 F.3d 1279, 1289 (Fed. Cir. 2008). That assumption, however, carries less weight when comparing a term in the claim to a term in the specification, especially where, as here, the specification only describes one embodiment. Cf. id. (“[T]here is nothing in the claims, the specification or the prosecution history that suggests that the preamble language ‘as it is being transferred’ has any different meaning than [the claim term] ‘prior to storage.’”).

Pentalpha supplies some evidentiary support for its proposed construction, but that support is not “highly persuasive” or sufficient to overcome the meaning that embraces the preferred embodiment. During prosecution of the '312 patent, the examiner rejected the proposed claims as anticipated by or obvious over U.S. Patent No. 4,672,179 (“Onishi”). Onishi discloses a rice cooker with the side walls of the pan and the side wall of the skirt separated by an adiabatic material, or a material that does not gain or lose heat:

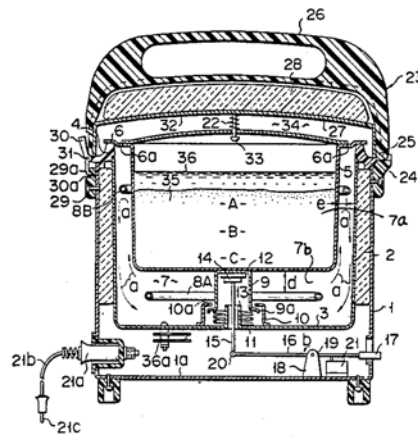

Onishi at Fig. 1, col.2 ll.49-53.

To distinguish Onishi, the applicant stated

in ONISHI . . . , the two walls 1 and 3 are separated by an adiabatic material 2 (whose nature is not specified) whereas in the case of the present invention, the outer plastic skirt 3 is completely free with respect to the pan 1 with the exception of a ring 5. This means that the space comprised between the skirt 3 and the pan 1 is entirely occupied by air and that there is no solid material therebetween.

A-119 (emphasis added). Pentalpha argues that SEB thereby narrowed the claim limitation “completely free” during prosecution and that the doctrine of prosecution disclaimer should preclude the district court’s construction. See N. Am. Container, Inc. v. Plastipak Packaging, Inc., 415 F.3d 1335, 1346 (Fed. Cir. 2005) (“[W]e have

previously explained that limitations may be construed to exclude a preferred embodiment if the prosecution history compels such a result.”).

Contrary to Pentalpha’s contentions, however, this court interprets this prosecution history as consistent with the district court’s claim construction. As noted, this also allows this court to account for the only embodiment provided in the ’312 patent’s specification. Thus, read in context, the applicant’s reference to “no solid material” refers only to the volume between the sides of the pan and skirt. As the quote from the prosecution history reveals, the applicant was only addressing the lack of “adiabatic material” in his invention to distinguish the Onishi reference. Indeed the applicant could not have intended his comment to preclude any solid material between the base of the pan and the base of the skirt because both Onishi and his own invention include a vertical stabilizing element.

Thus, this court does not read the prosecution history to alter or disclaim the district court’s interpretation of the claim language. Pentalpha’s attempt to create a disclaimer simply stretches this prosecution history too far. At most, the prosecution statement requires “completely free” to mean “no solid material between the sides of the pan and the sides of the skirt and no thermal bridges between the base of the skirt and the base of the pan.” The additional precision of this construction would also avoid the slight internal inconsistency of excepting the ring from the “completely free” limitation. In any event, this court detects no reversible error in the district court’s claim construction.

#### IV.

Following the jury verdict, Pentalpha moved for JMOL based on prosecution history estoppel, arguing that SEB's statements during prosecution should preclude any infringement by its modified deep fryer under the doctrine of equivalents. As noted, Pentalpha modified its deep fryer by replacing the ring that separates the skirt and the pan with six blocks. According to Pentalpha, the applicant's prosecution arguments during patent acquisition at the PTO preclude a finding that the six blocks are equivalent to the ring in claim 1. See Conoco, Inc. v. Energy & Env'tl. Int'l, L.C., 460 F.3d 1349, 1364 (Fed. Cir. 2006) ("To invoke argument-based estoppel . . . the prosecution history must evince a clear and unmistakable surrender of subject matter.").

Pentalpha did not seek JMOL on this ground at the close of evidence. Under Rule 50(b), a party may "renew" an earlier "request for judgment as a matter of law by filing a motion no later than 10 days after entry of judgment." Fed. R. Civ. P. 50(b); see Broadnax v. City of New Haven, 415 F.3d 265, 268 (2d Cir. 2005). If an issue is not raised in a previous motion for a directed verdict, however, this court's review is highly deferential. The Court of Appeals for the Second Circuit, whose law governs the procedural aspects of this case, see Bd. of Trustees of Leland Stanford Junior Univ. v. Roche Molecular Sys., Inc., 583 F.3d 832, 840 (Fed. Cir. 2009), requires that, in such a case, "a Rule 50(b) motion should not be granted unless it is required to prevent manifest injustice." Broadnax, 415 F.3d at 268 (quotation marks omitted).

During prosecution, the applicant argued that the claims were not obvious over Onishi in light of a Spanish reference ("Taurus"), which discloses a fryer with openings in the outer wall:

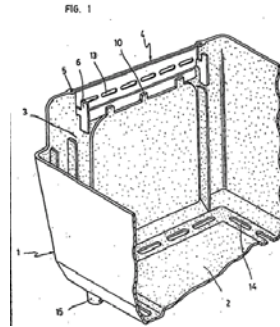

To distinguish Taurus, the applicant explained that cool outside air circulated through the above spaces between the inner and outer walls. This cooling mechanism is called convective cooling. Onishi, the applicant argued, relied on convective heating. Onishi itself explains that the heater heats the air in the heating space so as to uniformly heat the pot. Onishi col.1 ll.45-59. The applicant argued to the PTO that the teachings of Onishi and Taurus could not be combined to achieve the claimed deep fryer because neither convective “heating or cooling mechanisms has anything to do with the present invention.”

At trial, however, SEB’s expert, Charles Van Horn, testified that the temperature of the skirt in Pentalpha’s modified deep fryer might be kept at a low level in part due to hot air leaking out of the deep fryer. Specifically, Mr. Van Horn testified that the ring segments in the modified fryer did not completely close off the air space between the pan and the skirt. Moreover, he indicated that hot air escaped the modified fryer, although he did not know the rate of escape. And he affirmed that a deep fryer that has hot air leaking out of it will result in a cooler outside plastic wall than a deep fryer that does not. Pentalpha thus argues that its modified deep fryer cannot infringe under the doctrine of equivalents because the ring segments allow for the same convective cooling that SEB disavowed during prosecution of the '312 patent.

This court can assume, without deciding, that the applicant's statement during prosecution disclaimed any coverage of deep fryers that control the temperature of the outer wall through convective cooling. A reasonable jury could nonetheless conclude that Pentalpha's modified fryer does not rely on convective cooling to control the temperature of the skirt. The six large vent holes in Taurus that together span almost the entire width of the side wall do not readily compare to Pentalpha's modified fryer, which was presented to the jury and appears to allow only minimal air leakage. Mr. Van Horn's testimony about some hot air leakage does not compel the jury to find that the modified deep fryer relied on convective cooling to control the temperature of the wall. The jury might also reasonably conclude that the hot air leakage along the ring of the modified fryer did not appreciably contribute to controlling the temperature of the outer plastic wall. Because Pentalpha did not raise its JMOL motion in a timely fashion, this court must detect a manifest injustice before sustaining this untimely motion. With substantial questions about the operation of the modified fryer and Mr. Van Horn's vague testimony on convective cooling, this court detects no manifest injustice in honoring the jury's finding of infringement under the doctrine of equivalents.

This court also perceives no prejudice to Pentalpha in the district court's conclusion at the preliminary injunction stage that prosecution history estoppel did not apply. As discussed already, a preliminary injunction ruling is by nature only preliminary. Pentalpha had opportunities to renew its argument before the jury or to request a jury instruction estopping application of the doctrine of equivalents to a fryer that relies on convective cooling. Finally, Rule 50 at least required Pentalpha to raise its argument before the jury verdict. Broadnax, 415 F.3d at 268. By the time Pentalpha



filed its post-verdict JMOL motion, it was too late. And, as noted, this court discerns no material injustice in the jury's findings in this setting.

V.

The district court allowed SEB's expert, Mr. Van Horn, to testify over Pentalpha's objections. Pentalpha argued that Mr. Van Horn should be precluded from testifying as to infringement on the ground that he lacked expertise in the art of designing deep fryers. On appeal, Pentalpha argues that the district court's decision to admit Mr. Van Horn's testimony was an abuse of discretion.

The district court did not abuse its discretion by admitting Mr. Van Horn's testimony. This court will not disturb a district court's evidentiary rulings unless "manifestly erroneous." SR Int'l Bus. Ins. Co. v. World Trade Ctr. Props., LLC, 467 F.3d 107, 119 (2d Cir. 2006) (quotation omitted). District courts enjoy "wide latitude" to determine admissibility and "the mode and order" of evidentiary presentations. Id. In this case, the district court was in the best place to judge that Mr. Van Horn had the "knowledge, skill, experience, training, [and] education" of a "specialized" nature that was likely to "assist the trier of fact to understand the evidence or to determine" infringement. Fed. R. Evid. 702.

Mr. Van Horn has an undergraduate degree in chemical engineering from Lehigh University, a J.D. from American University, and an M.B.A. from George Washington University with a specialty in behavioral science. He worked in the U.S. Patent & Trademark Office for 31 years in various capacities, including as a patent examiner in the classes of fiber technology, electric photography, and structural and nonstructural laminates; as a supervisor in miscellaneous chemical technology; and as a director of

the organic chemistry and biotechnology group. Although he testified that he is not skilled in designing deep fryers, Mr. Van Horn explained that his experience was relevant because the claimed invention “involves the selection of particular . . . polymer material that have certain characteristics” and that “[m]ost of the areas [he has] worked in . . . have used polymers in one form or another.” Moreover Mr. Van Horn did not testify about deep frying per se, but instead described the importance of selecting a material for the ring or ring segments that would be resistant to the hot pan, as well as the importance of the spacing between the hot pan and the skirt. In light of the court’s claim construction, which, as discussed, included a reference to thermal bridges, Mr. Van Horn’s testimony established an adequate relationship between his experience and the claimed invention.

This case comes nowhere close to the unusual situation in Sundance, Inc. v. DeMonte Fabricating Ltd., 550 F.3d 1356 (Fed. Cir. 2008). In Sundance this court held that a district court abused its discretion when it admitted the testimony of a patent law expert “[d]espite the absence of any suggestion of relevant technical expertise.” Id. at 1361-62. Here, as explained, Mr. Van Horn had sufficient relevant technical expertise for the district court to allow him to testify. This court detects no abuse of discretion.

## VI.

Pentalpha also challenges the district court’s judgment under 35 U.S.C. § 271(a) and (b). As to § 271(a), direct infringement, Pentalpha challenges the district court’s jury instructions. As to § 271(b), inducement of infringement, Pentalpha contends that the district court erred in its JMOL rulings because Pentalpha had no actual knowledge of the patent during part of the time it was selling deep fryers to Sunbeam. See DSU

Med. Corp. v. JMS Co., 471 F.3d 1293, 1304 (Fed. Cir. 2006) (en banc) (“The requirement that the alleged infringer knew or should have known his actions would induce actual infringement necessarily includes the requirement that he or she knew of the patent.”) (emphasis added). Before addressing either of Pentalpha’s arguments, this court must determine if it needs to address direct infringement only, inducement of infringement only, or both.

Under the general verdict rule, where one or more of multiple claims is found legally invalid, a reviewing court must reverse and order a new trial if unable to determine whether the invalid theory tainted the verdict. AIG Global Sec. Lending Corp. v. Banc of America Sec. LLC, 646 F. Supp. 2d 385, 406 (S.D.N.Y. 2009) (collecting cases). That rule has also been held to apply in cases where the jury received multiple legal theories of liability. Id. (same).

Here, the jury received a verdict form with the label “special” rather than general. Using that verdict form, the jury found both direct infringement and inducement of infringement. Normally, such a verdict could support a damages award even if only one theory was correct. As long as the court can “determine” that “the verdict was based upon the [valid] theory,” the general verdict rule does not require a new trial. Id. A closer look at the damages question in this verdict form, however, along with the jury instructions, reveals a hopeless ambiguity.

The verdict form itself suggests that the jury was asked to base its damages calculation on inducement only. The verdict form asked, “What amount of damages in the form of a reasonable royalty do you find the plaintiff to have proven by a preponderance of the evidence with respect to deep fryers sold by Sunbeam, Fingerhut,

and Montgomery Ward?” J.A. 2508 (emphasis added). This instruction advised the jury to consider deep fryers sold by Pentalpha’s customers, as opposed to the deep fryers that Pentalpha sold to its customers. Therefore, this instruction could have led the jury to base the damages calculation on inducement alone.

On the other hand, the jury instructions also indicate that the jury could assess damages for direct infringement. The instructions stated:

The patent law specifically provides that the amount of damages that the Defendants must pay Plaintiff for infringing Plaintiff’s patent may not be less than a reasonable royalty for the use that the Defendants made of Plaintiff’s invention. You must determine what a reasonable royalty would be for the infringing sales of these Defendants and their subsidiaries.

J.A. 2484 (emphasis added). In contrast to the verdict form, the jury instructions required the jury to look to Pentalpha’s sales. This language requires a classic direct infringement analysis. See, e.g., Minco, Inc. v. Combustion Eng’g, Inc., 95 F.3d 1109, 1119 (Fed. Cir. 1996) (affirming a reasonable royalty award where “the district court awarded [the patentee] a royalty rate of 20% on the gross value of [the direct infringer’s] applicable sales”).

The record therefore does not clearly indicate that the jury found damages based on inducement alone, or based on direct infringement alone, or both. The general verdict rule requires that the only way this court can affirm in such a circumstance is by determining that the jury’s finding of both direct infringement and inducement of infringement was proper. As explained below, after carefully examining the record and the authority cited by both parties, this court discerns that this verdict satisfies that requirement and was proper on both counts.

A.

Section 271(a) makes it an act of infringement to “without authority make[], use[], offer[] to sell, or sell[] any patented invention, within the United States.” Pentalpha faults the jury instructions with respect to direct infringement on two grounds, each of which relates to the extraterritorial effect of U.S. patent law. First, Pentalpha argues that the district court should have charged the jury that an offer in the United States to sell goods outside of the United States would not violate the “offer to sell” provision of § 271(a). Second, Pentalpha argues that the district court erred by instructing the jury that, in determining if a sale occurred in the United States, it could consider “where the products were shipped from and where the products were shipped to.”

Pentalpha does not specify the point in the record showing an objection to these portions of the jury instructions. Fed. R. Civ. P. 51 requires a litigant to make a timely objection to a jury instruction in order to challenge that instruction on appeal. “The purpose of this Rule is to require the parties to give the trial court an adequate opportunity to cure any error in the instructions before the jury deliberates.” Metromedia Co. v. Fugazy, 983 F.2d 350, 363 (2d Cir. 1992). The United States Court of Appeals for the Second Circuit reviews jury instructions for which a timely objection is lacking for fundamental error. Fabri v. United Techs. Int’l, Inc., 387 F.3d 109, 121 (2d Cir. 2004). “Fundamental error is more egregious than the ‘plain’ error that can excuse a procedural default in a criminal trial and is so serious and flagrant that it goes to the very integrity of the trial.” Id. (quoting Jarvis v. Ford Motor Co., 283 F.3d 33, 62 (2d Cir. 2002)).

Neither of the alleged problems with the district court's jury instruction constitutes fundamental error. This court has yet to define the full territorial scope of the "offers to sell" offense in § 271(a). But see Rotec Indus., Inc. v. Mitsubishi Corp., 215 F.3d 1246, 1260 (Fed. Cir. 2000) (Newman, J., concurring) ("[A]n offer to sell a device or system whose actual sale can not infringe a United States patent is not an infringing act under § 271."). But even if this court had, Pentalpha's sales in this case did not so clearly occur overseas that the district court's failure to include such a limitation in its jury instructions affected the integrity of the trial.

To the contrary, the only evidence on which Pentalpha relies to argue that its sales occurred overseas was that it delivered its products to Sunbeam, Montgomery Ward, and Fingerhut f.o.b. Hong Kong or mainland China. This court has "rejected the notion that simply because goods were shipped f.o.b., the location of the 'sale' for the purposes of § 271 must be the location from which the goods were shipped." Lightcubes, 523 F.3d at 1370.

For the same reason, the district court's instruction that the jury could consider "where the products were shipped from and where the products were shipped to" in determining if a sale occurred in the United States was not a fundamental error. If anything, the jury instructions helped Pentalpha: the court instructed the jury that it could consider the f.o.b. terms, even though those terms were not dispositive. Other than the f.o.b. terms in the invoices presented to the jury, the record shows that Pentalpha intended to sell its deep fryers directly into the United States. Pentalpha itself affixed the American trademarks of Sunbeam, Montgomery Ward, and Fingerhut to the deep fryers, and it manufactured the deep fryers with North American electrical

fittings. Moreover, the invoices between Pentalpha and the three U.S. companies all identify delivery to U.S. destinations. In sum, this court does not perceive any fundamental error with the jury instructions in light of the record evidence.

B.

“Whoever actively induces infringement of a patent shall be liable as an infringer.” 35 U.S.C. § 271(b). In DSU Medical, which was decided after the jury verdict in this case, this court addressed the intent necessary to support a finding of induced infringement. Under that rule, the plaintiff must show that the alleged infringer knew or should have known that his actions would induce actual infringements. 471 F.3d at 1304. This court further stated that “[t]he requirement that the alleged infringer knew or should have known his actions would induce actual infringement necessarily includes the requirement that he or she knew of the patent.” Id. (emphasis added). This court’s opinion did not, however, set out the metes and bounds of the knowledge-of-the-patent requirement. Compare Insituform Techs., Inc. v. CAT Contracting, Inc., 161 F.3d 688, 695 (Fed. Cir. 1998) (“A crucial element of induced infringement is that the inducer must have actual or constructive knowledge of the patent.”) (emphasis added).\*

The facts of DSU Medical did not require this court to address the scope of the knowledge requirement for intent. Instead, the court resolved conflicting case law setting forth both a requirement to knowingly induce infringement and to merely knowingly induce the acts that constitute direct infringement. Id. at 1306. In other

---

\* SEB contends that this court need not reach this issue because the district court reduced the damages award by \$2 million based on SEB’s settlement with Sunbeam and thus eliminated all damages for pre-notice sales. The record indicates that the district court did not attribute the reduction to any particular Sunbeam sales. Therefore this court has no way to ascertain on appeal if the reduction precludes the knowledge and intent issue.

words, the court decided the target of the knowledge, not the nature of that knowledge. As Chief Judge Michel's concurring opinion noted, the record in DSU Medical showed that the alleged infringer had actual knowledge of the patent-in-suit. Id. at 1311. "Accordingly, the 'knowledge of the patent' issue [was] not before us." Id.

This court has made clear, however, that inducement requires a showing of "specific intent to encourage another's infringement." Broadcom Corp. v. Qualcomm Inc., 543 F.3d 683, 699 (Fed. Cir. 2008) (quoting DSU Medical, 471 F.3d at 1306). As other courts have observed, "specific intent" in the civil context is not so narrow as to allow an accused wrongdoer to actively disregard a known risk that an element of the offense exists. See Crawford-EI v. Britton, 951 F.2d 1314, 1318 (D.C. Cir. 1991) (equating specific intent and deliberate indifference); Boim v. Holy Land Found. for Relief & Dev., 549 F.3d 685, 693 (7th Cir. 2008) (equating intentional misconduct with knowledge and deliberate indifference).

Pentalpha argues that the court in DSU Medical did not mean "knew or should have known of the patent" because the decision states "knew of the patent." See 471 F.3d at 1304. At the outset, this court notes that the Supreme Court has indicated, in a different civil context, that "deliberate indifference" is not necessarily a "should have known" standard. Farmer v. Brennan, 511 U.S. 825, 840 (1994). The latter implies a solely objective test, whereas the former may require a subjective determination that the defendant knew of and disregarded the overt risk that an element of the offense existed. See id. ("'[D]eliberate' is better read as implying knowledge of a risk, [but] the concept of constructive knowledge is familiar enough that the term 'deliberate indifference' would not, of its own force, preclude a scheme that conclusively presumed awareness from a



risk's obviousness." For example, an accused infringer may defeat a showing of subjective deliberate indifference to the existence of a patent where it shows that it was genuinely "unaware even of an obvious risk." Id. at 844. More importantly, and as courts have observed in a variety of settings, the standard of deliberate indifference of a known risk is not different from actual knowledge, but is a form of actual knowledge. See, e.g., United States v. Carani, 492 F.3d 867, 873 (7th Cir. 2007) ("Deliberate avoidance is not a standard less than knowledge; it is simply another way that knowledge may be proved."); Woodman v. WWOR-TV, Inc., 411 F.3d 69, 84 n.14 (2d Cir. 2005) ("We note that a party's knowledge of a disputed fact may also be proved through evidence that he consciously avoided knowledge of what would otherwise have been obvious [to] him.").

In this case, this court must determine whether the district court erred in denying Pentalpha's motion for JMOL where the record shows no direct evidence that Pentalpha had actual knowledge of the patent before April 9, 1998. The standard of review following the denial of JMOL is de novo. Fabri, 387 F.3d at 119. Nevertheless, this court must apply the same standard as the district court, which is deferential to the jury's verdict. AMW Materials Testing, Inc. v. Town of Babylon, 584 F.3d 436, 456 (2d Cir. 2009). A grant of JMOL is appropriate only where a reasonable jury would not have a legally sufficient evidentiary basis to find for the non-movant on the issue. Agrizap, Inc. v. Woodstream Corp., 520 F.3d 1337, 1342 (Fed. Cir. 2008) (citing Fed. R. Civ. P. 50(a)). For that reason,

[w]e will reverse the denial of a motion for judgment as a matter of law only when there is such a complete absence of evidence supporting the verdict that the jury's findings could only have been the result of sheer surmise and conjecture, or where there is such an overwhelming amount

of evidence in favor of the moving party that fair minded jurors could not reasonably arrive at a verdict against the movant.

SR Int'l, 467 F.3d at 118-119 (internal quotation marks and alterations omitted).

As just explained, a claim for inducement is viable even where the patentee has not produced direct evidence that the accused infringer actually knew of the patent-in-suit. This case shows such an instance. The record contains adequate evidence to support a conclusion that Pentalpha deliberately disregarded a known risk that SEB had a protective patent. The jury heard evidence that Pentalpha purchased an SEB deep fryer in Hong Kong and copied all but the cosmetics. The owner of a company related to Pentalpha testified that Pentalpha's engineer took a T-Fal deep fryer and used "the same ring that separates . . . the wall making it a cool touch unit and the construction, basically everything the same; thermostat, it was the same; the timer was the same, just a little bit different on the cosmetics of the outside appearance for the deep fryer." Again, the record shows that Pentalpha hired an attorney to conduct a right-to-use study, but did not tell him that it had based its product on SEB's product.

A failure to inform one's counsel of copying would be highly suggestive of deliberate indifference in most circumstances. Here, the jury also heard testimony that indicated that Pentalpha's president, John Sham, was well versed in the U.S. patent system and understood SEB to be cognizant of patent rights as well. Sham testified that he was the named inventor on 29 U.S. patents and that Pentalpha and SEB had an earlier business relationship that involved one of Pentalpha's patented steamer products. The record thus contains considerable evidence of deliberate indifference.

In contrast, Pentalpha did not produce any exculpatory evidence. As noted, proof of knowledge through a showing of deliberate indifference may be defeated where

an accused infringer establishes that he actually believed that a patent covering the accused product did not exist. But here Pentalpha did not argue that it or its employees actually believed that an SEB patent did not exist. Pentalpha's brief implies that it should be excused because the SEB deep fryer that it copied was not marked with a U.S. patent number. But Pentalpha does not argue that it relied on the lack of a mark to come to a belief that the deep fryer was not patented. And even if it had, such an argument would likely lack credibility unless it were supplemented by an explanation for why one would expect an SEB deep fryer purchased in Hong Kong to have U.S. patent markings.

This opinion does not purport to establish the outer limits of the type of knowledge needed for inducement. For instance, a patentee may perhaps only need to show, as Insituform suggests, constructive knowledge with persuasive evidence of disregard for clear patent markings, similar to the constructive notice requirement in § 287(a). See infra Part VII. This court does not set those boundaries now, just as it did not set them in DSU Medical. Here, the record establishes sufficient support for the conclusion that Pentalpha deliberately ignored the risk that SEB had a patent that covered its deep fryer. Thus, the jury's finding of inducement is justified, and the damage award, even if it was based on inducement alone, stands.

## VII.

Pentalpha also challenges the damages award on the basis that, contrary to § 287(a), the record did not show that SEB marked "substantially all" of its deep fryers before July 10, 1998. Pentalpha also sought a reduction in damages, alleging that the

record shows that SEB withheld documents related to marking. The district court declined to reduce the award on either ground.

Under § 287(a) a patentee that sells its patented product within the United States must provide actual or constructive notice of the patent to the accused infringer to qualify for damages. Sentry Prot. Prods., Inc. v. Eagle Mfg. Co., 400 F.3d 910, 918 (Fed. Cir. 2005). Constructive notice requires the record to show that “the patentee consistently marks substantially all of its patented products.” Id.

At trial, an SEB executive, Gregers Infeld, affirmed that “to the best of [his] knowledge” SEB’s deep fryers were “always” marked and that SEB had a policy of marking its products. SEB also put into evidence one of its deep fryers with an unknown manufacturing date that had a sticker that listed the ’312 patent. On cross examination, however, Infeld testified that “there was a batch of products where the patent marking wasn’t on.” In addition to that testimony on cross, Pentalpha also relies heavily on Infeld’s admission, at his deposition, that he had no knowledge of SEB’s marking practices.

Once again, the district court properly denied Pentalpha’s motions for JMOL. The record supplies sufficient evidence to support the jury’s conclusion that SEB consistently marked substantially all of its deep fryers. Indeed, the record at trial did not even contain Infeld’s deposition testimony. In any event, the record supports the jury verdict.

Pentalpha contends that discovery misconduct justifies a reduction in the damage award. The discovery dispute at issue extends back five years before trial. In May of 2001, Pentalpha served discovery requests seeking, among other things,

documents relating to, and a Rule 30(b)(6) witness with knowledge of, SEB's patent marking practices. SEB produced only a one-page document: a picture of a sample sticker that listed the '312 patent. SEB objected to the Rule 30(b)(6) request. Pentalpha filed a motion to compel in response to SEB's objection. On October 5, 2001, Magistrate Judge Yanthis, who had been appointed to oversee discovery, refused to consider the motion to compel due to the parties' failure to meet and confer.

The marking issue arose again with Pentalpha's motion in limine, filed four-and-a-half years later, in which Pentalpha moved to exclude any evidence related to marking at trial. At the hearing on the motion, SEB's counsel asserted that there were "no other documents" concerning patent markings. Accordingly, the district court denied Pentalpha's motion, but noted that "[i]f witnesses on the stand say there are other documents, we've got a different issue before us."

At trial, Infeld testified that SEB's factories print the stickers found on its deep fryers based on a "list which shows [the factories] exactly what needs to be put on" and that the compilation of that list required a lot of paperwork. Pentalpha relied on that testimony in its post-verdict JMOL to argue that SEB did not produce documents related to marking, namely, the paperwork needed to compile the sticker list. The district court denied Pentalpha's motion on the ground that Pentalpha had delayed too long in seeking these documents and did not raise the issue immediately after Infeld's trial testimony. JMOL Opinion, 2007 WL 3165783, at \*2.

The district court did not abuse its discretion in denying Pentalpha's motion for JMOL on discovery misconduct grounds. Pentalpha clearly forfeited the issue, if not during its four-and-a-half year silence before trial, then when it did not object during trial

following Infeld's testimony. Pentalpha cannot "fail to prepare [its] case[] adequately and then seek to remedy the defects after judgment." Korea First Bank v. Lee, 14 F. Supp. 2d 530, 532-33 (S.D.N.Y. 1998).

#### VIII.

Finally, Pentalpha appeals the district court's denial of its motion for new trial, which was based on SEB's attorney's allegedly improper argument during his closing argument on reasonable royalty damages. As a part of its damages case, SEB relied on a price list that listed its "cool wall" deep fryers at around \$40 per unit. But an SEB executive testified at trial that, although he thought SEB made a profit, SEB did not always sell its deep fryers at the list prices. Relying on that testimony, Pentalpha moved for JMOL at the close of evidence on SEB's claim for lost profits. The district court granted that motion, concluding that "[t]here's nothing in the record, in my view, from which [the jury] could say, 'this is what a single deep fryer sold for.'" The district court allowed SEB's claim for damages based on a reasonable royalty to reach the jury.

During summation on its reasonable royalty claim, SEB's attorney argued that SEB was making a "substantial profit" through its deep fryers, that it "got something close to [its] list prices", and that it "sought to obtain a gross margin of about 40 to 45 percent of the selling price." Pentalpha objected during and after the summation on the basis that the court had already rejected SEB's claim for lost profits. SEB's arguments with respect to a reasonable royalty, Pentalpha argued, were just another version of its baseless lost profit argument. The district court overruled Pentalpha's objections, but warned the jury that its "recollection of what the witness has said what a gross margin was and what a profit was in this case is what should control."

“[W]e will reverse a district court’s decision to grant or deny a motion for a new trial only for an abuse of discretion.” Song v. Ives Labs., Inc., 957 F.2d 1041, 1047 (2d Cir. 1992). Reasonable royalty damages postulate a hypothetical negotiation between a willing licensor and licensee at the time of infringement. Minco, 95 F.3d at 1119. “This hypothetical construct seeks the percentage of sales or profit likely to have induced the hypothetical negotiators to license use of the invention.” Id. In denying Pentalpha’s motion for a new trial, the district court held that although “the Court ruled that [lost profits] had not been shown with sufficient exactness . . . this does not mean that the jury could not consider SEB’s expectations of profits as part of a hypothetical negotiation.” JMOL Opinion, 2007 WL 3165783, at \*7 (citing Georgia-Pacific Corp. v. U.S. Plywood Corp., 318 F. Supp. 1116, 1120 (S.D.N.Y. 1970)).

The district court did not abuse its discretion in declining to grant a new trial to Pentalpha based on the summation of SEB’s counsel. The record adequately supports SEB’s argument that it sought to obtain a gross margin of about 40 to 45 percent of the list price. There is a difference between an expectation of success and actual success at achieving a certain margin, and that difference is relevant in calculating the hypothetical negotiation. But this court sees no reason to preclude a jury from hearing attorney argument based on an expectation of success, particularly when Pentalpha had every opportunity to respond by highlighting to the jury that SEB’s stated gross margin was only an expectation and that, absent established commercial success at that rate, the hypothetical negotiation should result in a lower rate. SEB’s argumentative efforts to frame the hypothetical negotiation in its favor were not

improper. Moreover the district court did not abuse its discretion in denying a new trial on this basis.

## IX.

SEB cross appeals the district court's decision to set aside its original awards of enhanced damages and attorneys' fees. Those awards were based on the jury's finding of willfulness, JMOL Opinion, 2007 WL 3165783, at \*10-12, but the district court vacated them in light of this court's intervening opinion in Seagate, Enhanced Damages Opinion, 2008 WL 4540416, at \*4.

In Seagate, this court set out a new test for willful infringement. It overruled the affirmative duty of due care set forth in Underwater Devices Inc. v. Morrison-Knudsen Co., 717 F.2d 1380, 1389-90 (Fed. Cir. 1983), and held that proof of willful infringement requires a patentee to show by clear and convincing evidence that, as a threshold matter, "the infringer acted despite an objectively high likelihood that its actions constituted infringement of a valid patent." 497 F.3d at 1371. The district court, proceeding under pre-Seagate law, instructed the jury that a potential infringer "has an affirmative duty of due care not to infringe" a known patent, and that failure to abide by that duty constituted willful infringement. The jury found Pentalpha's infringement willful.

In vacating its award of enhanced damages and attorneys' fees, the district court held:

The record contains evidence from which a jury could find that the Seagate standard of objective recklessness is satisfied. . . . The evidence regarding Pentalpha's willfulness, however, is not so one-sided or overwhelming to allow the Court to conclude that a jury, properly instructed under the new Seagate standard, was required to find, by clear and convincing evidence, willful infringement.



Enhanced Damages Opinion, 2008 WL 4540416, at \*3. This court detects no reversible error in this analysis.

Importantly, SEB does not ask this court to order a new trial on willfulness. Had it asked, this court might have granted the request in light of the district court's conclusion that the willfulness verdict could have gone either way under the Seagate test. "An erroneous instruction, unless harmless, requires a new trial." Anderson v. Branen, 17 F.3d 552, 556 (2d Cir. 1994); see Voda v. Cordis Corp., 536 F.3d 1311, 1328 (Fed. Cir. 2008) (remanding and noting that the district court "may at its discretion assess Voda's evidence of willful infringement under the [intervening] Seagate standard to determine whether a new trial on willfulness is necessary"). Instead, SEB argues that the evidence on willfulness is so strong that the district court erred in vacating the enhanced damages and attorneys' fees awards. This court agrees with the district court that SEB's evidence is not so strong that SEB is entitled to a finding of willful infringement as a matter of law.

SEB also argues that there were factors other than willful infringement that warranted an award of attorneys' fees, focusing primarily on alleged litigation misconduct. But the district court apparently did not find any litigation misconduct sufficient to warrant an award of attorneys' fees. Enhanced Damages Opinion, 2008 WL 4540416, at \*4. Moreover this court declines to impose attorneys' fees on a different basis than ordered by the district court.

Finally, SEB appeals the district court's modification of a pre-judgment attachment in light of its ruling with respect to Seagate, but makes no arguments in its

briefs with respect to that appeal. Any claim of error with respect to that modification is therefore waived.

X.

For the foregoing reasons, the judgment of the United States District Court for the Southern District of New York is affirmed.

AFFIRMED.

COSTS

Each party shall bear its own costs.